

# 19

## Epilogue

Ulf Dieckmann, Diethard Tautz, Michael Doebeli,  
and Johan A.J. Metz

When Terry Erwin from the Smithsonian National Museum of Natural History examined the diversity of beetles that lived on a single species of tropical trees, he found 682 different beetle species, 163 of which he classified as specialist species that lived exclusively on the particular tree species used in his study. Since there are around 50 000 tropical trees species, Erwin extrapolated that there must be on the order of 7 million specialist beetle species (Erwin 1982). Using similar extrapolations, Erwin (1982) also estimated the total number of tropical arthropod species as about 30 000 000. While these estimates may be too high (Schilthuizen 2000; Ødegaard 2000; Novotny *et al.* 2002), they are mind-boggling nevertheless and serve as an illustration of the incredible amount of species diversity that exists on our planet: estimates for the total number of extant species of plants and animals range from 10 million to 100 million (May 1990; Schilthuizen 2000). It is also estimated that the number of extant species represents only about 1% of the total number of species that ever existed during the history of life on earth. Together with the common phylogenetic ancestry usually inferred for the tree of life for higher organisms, this implies that speciation must have been truly rampant during the creation and evolution of our biosphere.

Indeed, there was ample space and time for the evolutionary generation of diversity. After all, the past 3.5 billion years, during which life presumably evolved from some self-replicating molecules, has seen large-scale geographic changes, including the rise, shift, and disappearance of continents and oceans. For example, the fauna and flora of Australia is in many ways very different from that of any other place in the world, presumably because of the long-lasting geographic isolation of this continent from other landmasses.

### 19.1 The Allopatric Dogma

By scaling down to smaller geographic areas, one arrives at the allopatric speciation model. According to this perspective, speciation occurs when subpopulations of a single ancestral population become geographically isolated and embark on different evolutionary trajectories. During separate long-term evolution in geographic isolation, reproductive isolation evolves as a by-product of divergence in other aspects of an organism's phenotype or genotype. When, at some later point in time,

secondary contact occurs between the diverging species, so that their ranges overlap again, hybrid inferiority may reinforce reproductive isolation, but the primary cause of speciation in this scenario remains long-term geographic isolation.

Prominent evolutionary biologists, such as Theodosius Dobzhansky and Ernst Mayr, strongly promoted this type of speciation as the main mode of evolutionary diversification, to the point of ridiculing alternative scenarios, as evidenced by Dobzhansky's remark that sympatric speciation, that is, speciation unfolding in the absence of geographic isolation, "is like the measles; everyone gets it and we all get over it" (Bush 1998). Indeed, it is now the widely accepted common wisdom that most evolutionary diversification occurred according to the allopatric speciation scenario.

However, even though allopatric speciation, with its apparent simplicity, is an intuitively appealing idea, a number of problems reveal themselves upon closer inspection. For one thing, allopatric speciation is not really simple conceptually, because the mechanisms that underlie the evolution of reproductive isolation as a by-product of divergence in other traits are understood only poorly, both empirically and theoretically. In particular, some closely related species (e.g., North American and European buffaloes) have evolved in allopatry for millions of years, but readily interbreed when brought into contact. Moreover, other species, such as oak, have long evolved in sympatric ranges and clearly maintained their phenotypic and genetic identity, yet they can interbreed easily. It seems, then, that by-product reproductive isolation is a far more complicated concept than implied by allopatric speciation theories. It is also commonly acknowledged that – except when driven by sexual arms races (Schilthuizen 2001) – allopatric speciation is a very slow process, because it involves neither inherent selection for differentiation, nor selection for isolating mating mechanisms. This, combined with need to postulate billions of geographic events to create the isolation between subpopulations of ancestral species, casts serious doubts on the ubiquity of allopatric speciation.

## 19.2 Adaptive Speciation

Perhaps the most convincing counterarguments against the supreme rule of allopatric mechanisms come from theoretical developments which show that speciation in sympatry, that is, under conditions of ecological contact, is an entirely plausible evolutionary scenario. Models of adaptive speciation show that many types of frequency-dependent biological interactions can readily cause the dynamic emergence of disruptive selection in an evolving population, and disruptive selection can in turn readily induce adaptations that result in diminished gene flow between sympatrically diverging subpopulations. Part A of this book is devoted to explaining the theory of adaptive speciation in some detail. The theory is developed within the framework of adaptive dynamics, and is based on the phenomenon of evolutionary branching. The basic notions used in this theoretical framework for the study of evolutionary dynamics in phenotype space are explained in Chapter 4, which focuses on asexual populations. Combining this with population genetic

modeling leads to a fully fledged theory of adaptive speciation in sexual populations, both under completely sympatric conditions (Chapter 5) and in geographically structured populations with spatially localized gene flow (Chapter 7). The models presented in Part A of this book show that adaptive speciation under sympatric conditions can no longer be dismissed on theoretical grounds.

The theory of adaptive speciation advanced here arises from a confluence of earlier developments. In particular, the notion that frequency-dependent selection can induce sympatric speciation has been highlighted already in previous models, based on the assumption that reproductive isolation can be pleiotropically induced by adaptation to different local habitats. These Levene-type models are reviewed in Chapter 3, and many of them are, in turn, based on one of the early paradigms of sympatric speciation: host shifts and host-race formation in insects (Bush 1969; Feder 1998). The theory of adaptive speciation extends these early models by showing that disruptive selection does not occur only under rather special assumptions about pleiotropic fitness interactions in two different habitats. Rather, the dynamic emergence of disruptive selection during the course of gradual evolution is a robust consequence of frequency-dependent interactions of many different kinds, including all the basic types of ecological interactions, as well as interactions that lead to sexual selection and sexual conflict (Chapter 5). That frequency-dependent ecological interactions can often lead to the dynamic emergence of fitness minima has been foreshadowed in earlier work (Rosenzweig 1978; Eshel 1983; Taylor 1989; Christiansen 1991; Brown and Pavlovic 1992; Abrams *et al.* 1993a), but until recently neither its ubiquity nor its significance for the theory of speciation had been appreciated fully.

This may, in part, arise from the focus on studying the mean and variance of quantitative genetic traits (Lande 1979b), an approach that makes it difficult to model evolutionary processes through which the trait's frequency distribution can become bimodal. Also, when approaching the problem from the population genetics' aspect, the simplifying assumptions turn out to be restrictive. Study of the evolution of isolating mating mechanisms in Levene-type models with deterministic dynamics that involved at most a few loci had initially cast doubt on the feasibility of sympatric speciation (Felsenstein 1981; Seger 1985a), and thus reinvigorated the case for allopatric speciation. In rather stark contrast, individual-based stochastic models of adaptive dynamics that incorporate multilocus genetics reveal that the evolution of various types of isolating mating mechanisms occurs generically and with relative ease once disruptive selection has emerged dynamically in a sexual population.

We thus see the theory of adaptive speciation as an extension of this earlier work, based on a less restrictive genetic modeling of reproductive processes, as well as on advances in our understanding of the ecological causes of evolutionary diversification that result from an integrated approach to phenotypic evolution under frequency-dependent selection. These developments have led to a unifying framework for theoretical investigations of adaptive diversification, which may challenge the perception of allopatric speciation as the only viable scenario.

### 19.3 Diversity of Speciation Processes

Freeing research on species formation from the straitjacket imposed by considering such processes allopatric unless unequivocally proved otherwise refocuses our attention onto the great richness and exciting complexity of speciation processes. To appreciate this richness it must be recognized that speciation processes – far from being the single events they present themselves as to the evolutionary taxonomist – have a temporal and spatial extension that allows them to involve multiple phases in time and/or multiple domains in space. In particular, species may originate against a background of allopatric, parapatric, and sympatric distribution patterns, and the results of such a pattern-oriented classification may differ when applied to successive stages of the speciation process. The same holds for the process-oriented distinction between adaptive and nonadaptive mechanisms of speciation: here, too, the classification may differ between stages, or possibly even between domains, of unfolding speciation dynamics. In general, the perception of speciation as a potentially multilayered process offers a healthy antidote against becoming caught up in semantic controversies about rigid dichotomies.

We are thus compelled to be more pragmatic about the classification of speciation processes, because it is unlikely that the complexity of these processes can be captured in a single binary distinction. The long-standing debate as to the prevailing mode of speciation focused primarily on spatial patterns of population distributions and championed nonadaptive mechanisms of speciation (genetic drift, or separate local adaptation to disconnected habitats with pleiotropic implications for reproductive isolation). In this traditional view, reproductive isolation emerges as a by-product of other factors and is not by itself adaptive. By contrast, many chapters in this book illustrate how reproductive isolation can be selected for directly through natural and sexual selection. This alternative view incorporates processes of reinforcement as special cases that can occur after a primary allopatric phase has already created a situation of partial reproductive isolation, which is brought to completion through selection against hybrids and for assortative mating. Discussions in this volume highlight that a primary allopatric phase is entirely dispensable: reproductive isolation can also be selected for in continual sympatry.

This leads to the conclusion that we can characterize speciation processes adequately only by utilizing various dichotomies complementarily: allopatric versus sympatric, nonadaptive versus adaptive, speciation driven by natural versus sexual selection, speciation with and without ecological character displacement, etc. It is also clear that, sometimes, these distinctions can be attributed meaningfully to individual process phases only and not necessarily to the speciation process as a whole. At first sight, this may seem like a plea for unwieldy conceptual intricacy. Instead, we suggest that this recognition provides a fascinating opportunity to achieve a greater (and more encompassing) unity in our description of speciation processes. Aspects of spatial structure and pattern formation, of ecological character displacement and limiting similarity, and of reproductive isolation and assortative mating are often dynamically and inextricably linked when speciation

processes run their course. Based on this recognition, we propose to unfold the resultant continuum of possible speciation scenarios along three fundamental axes: spatial differentiation, ecological differentiation, and mating differentiation. As explained in more detail in Box 19.1, this allows us to look at alternative evolutionary pathways of species formation within a common conceptual framework. All traditionally acknowledged speciation mechanisms, as well as those described in this book, are accommodated readily in this broadened classification scheme.

#### 19.4 Empirical Studies of Speciation

The natural diversity of speciation patterns and processes is captured in the empirical chapters of Parts B and C. These deal with examples from very different systems and perspectives, and reflect the broadness of the speciation scenarios encountered in nature. None of these studies were conducted with the theory of adaptive speciation in mind, but they can be seen as starting points to disentangle the diversity of processes into the basic components depicted in Box 19.1.

The chapters in Part B deal with cases of recent or ongoing genetic divergence under conditions of contact, which is where one can hope to find the best evidence for the adaptive speciation scenario. However, each of the chapters deals with settings in which alternative or additional components must be considered. For example, although the three chapters on fish systems deal with very recent splitting events, they come to different conclusions with respect to the primacy of the process that causes speciation. While sexual selection is suggested as the primary driving force for the haplochromine cichlids in African lakes (Chapter 8), the plasticity of the pharyngeal jaw apparatus is also implicated as an additional factor that facilitates quick adaptation to new ecological niches. The stickleback study (Chapter 9) is an excellent example of the interplay between primary allopatric divergence and secondary contact that leads to niche partitioning. And in the arctic charr (Chapter 10), the complexity of the available niches after the postglacial reinvasion of volcanic lakes provides a level of resource polymorphism that is expected to promote the fast generation of newly adapted morphs. Adaptive speciation mechanisms are likely to play a role in all three of these cases, but the actual natural settings will inevitably always be more complex than the idealized world of theoretical abstractions.

The chapters in Part C look at the natural patterns of speciation, including those from phylogeography and paleontology. To infer past processes from extant pattern is an old exercise in speciation research, but to use the knowledge of processes to interpret patterns may be equally enlightening. For example, the paleontological analysis of the repeated radiations of semionotid fish in mesozoic rift lakes (Chapter 18) shows that most evolutionary novelties arose very quickly after the colonization of the lake. This is difficult to explain with a conventional allopatric model, but it is perfectly in line with predictions from the theory of adaptive speciation. Niche partitioning under conditions of disruptive selection is expected to be most efficient during an initial colonization phase, when ecological opportunities abound and evolutionary pathways are less constrained.

### Box 19.1 A process-based classification of speciation routes

Realizing that the dichotomies traditionally applied to describe speciation processes are too coarse, here we propose an extended classification scheme. It encompasses that speciation, in general, can be driven by or lead to differentiation between the incipient species in terms of their spatial distributions, their ecological role, and their mating and interbreeding options.

The graphs below therefore simultaneously utilize continuous axes for spatial differentiation (front to back), ecological differentiation (left to right), and mating differentiation (bottom to top). At the onset of speciation, populations are undifferentiated, which corresponds to a starting point at the origin (i.e., in the lower left front corner) of each panel (open circles).

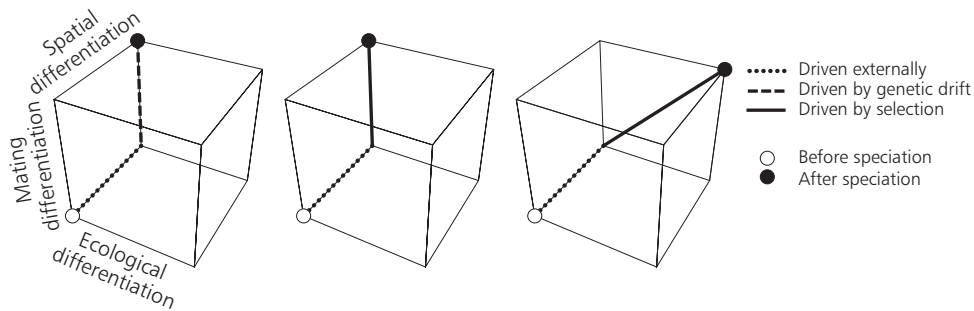

In classic allopatric speciation scenarios, external causes first result in geographic isolation between two incipient species, and thus introduce a high degree of spatial differentiation (dotted lines). After that, either genetic drift (dashed line in left panel above; Sections 6.2 and 6.6, and Box 6.5) or sexual selection and/or conflict (continuous line in middle panel above; Section 6.6, and Box 6.5) can increase mating differentiation. Alternatively, local adaptation with pleiotropic effects on mating can increase ecological and mating differentiation concomitantly (continuous line in right panel above; Sections 7.2, 8.4, 10.4, 11.6, and 13.2 to 13.3, and Box 13.1). In all three cases, the incipient species become reproductively isolated at the end of these speciation trajectories (filled circles).

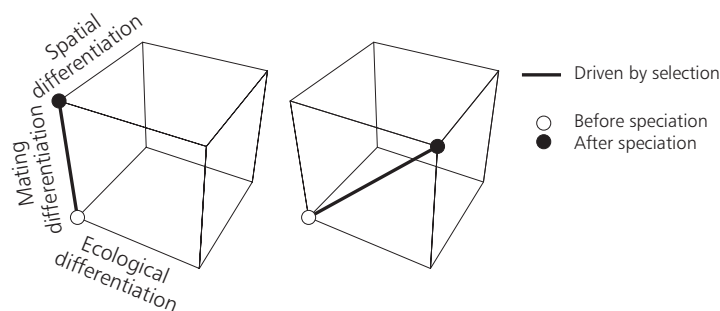

Sympatric speciation scenarios, in contrast, do not require that external causes, as a first step, lead to geographic isolation. For populations that lack any spatial structure, two scenarios have been suggested: either evolution driven by sexual selection and/or conflict induces reproductive isolation in the absence of concomitant ecological differentiation (left panel above; Sections 3.3, 5.4, and 8.2 to 8.4) or such

*continued*

**Box 19.1** *continued*

ecological differentiation is accompanied by the evolution of assortative mating (right panel above; Sections 3.3, 5.2, and 5.3). While the first of these cases draws its motivation from the explosive radiation of cichlid color morphs in African lakes, it is doubtful that morphs differentiated only with respect to their mating characteristics, and not ecologically or spatially, can coexist on an ecological time scale: a large proportion of the resultant species are thus likely to be ephemeral only.

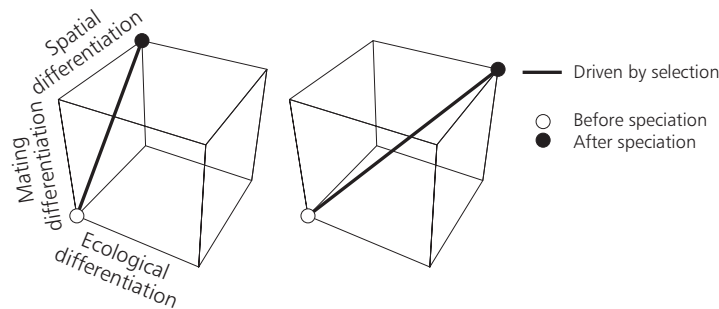

Introducing a spatial extension, and thus the opportunity for populations to differentiate spatially, extends models of sympatric speciation. If the resultant models are classified according to where the speciation mechanism operates, they can still be called sympatric, whereas judged from the spatial pattern that the speciation process generates they might be termed parapatric. This ambiguity underscores that features like allopatric, parapatric, and sympatric can be attributed meaningfully only to particular stages of speciation processes. Again, we have to consider two cases: either evolution driven by sexual selection and/or conflict induces reproductive isolation and spatial differentiation by giving rise to mating domains (left panel above; Section 15.3; Boxes 7.5 and 15.1), or ecological differentiation is accompanied by the evolution of assortative mating and the emergence of spatial differentiation (right panel above). The latter type of speciation process can occur at least in two guises: first, in the course of host-race formation (Sections 3.4, 11.5 to 11.6, 12.2 to 12.4, and Box 11.1) and, second, through local adaptation and speciation along environmental gradients (Sections 7.3 and 7.4).

The speciation processes considered so far are all examples of one-phase processes (provided we do not count the imposition of geographic isolation in allopatric scenarios as a separate phase). Given these process “atoms”, as the next step we can classify those slightly more complex speciation processes in which two phases are involved. This is accomplished easily, as the examples below illustrate.

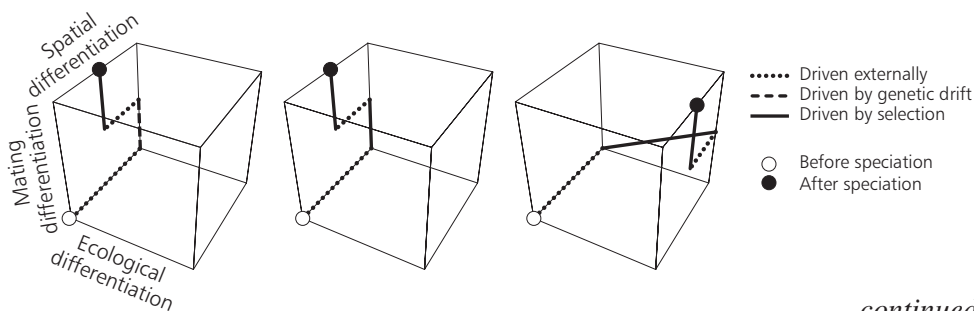
*continued*

**Box 19.1** *continued*

The three panels above show alternative scenarios in which allopatric speciation is brought to completion by reinforcement (Sections 7.2, 9.4, and 11.6). In the wake of geographic isolation (dotted long lines), the incipient species develop partial reproductive isolation, through genetic drift (left panel above), through sexual selection and/or conflict (middle panel above), or through local ecological adaptation (right panel above). This first phase is followed by the establishment of secondary contact (dotted short lines) and subsequent reinforcement (upper continuous lines).

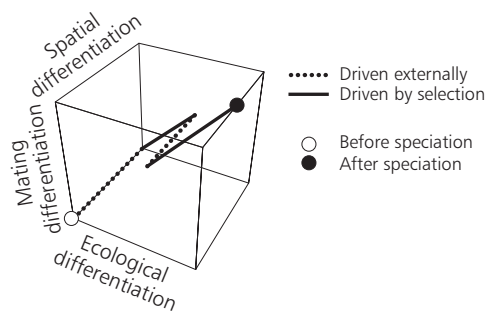

The panel above shows another two-phase speciation process. This time, evolution during a first phase after geographic isolation results in partial ecological differentiation and partial mating differentiation (lower continuous line). In a second phase, contact between the incipient species is reestablished, and further ecological and mating differentiation ensues (upper continuous line); the second phase may also involve an increase in spatial differentiation. A process of this type is favored currently to explain the sympatric occurrence of limnetic and benthic forms of sticklebacks in some Canadian lakes (Sections 9.3 to 9.4, and Boxes 9.1, 9.2, 9.4, and 9.5).

It is evident that the classification scheme proposed here can accommodate even more complex types of speciation processes that involve, for example, three consecutive phases until speciation is completed. Speciation in asexual organisms is another special case: since no mating differentiation evolves, speciation trajectories are restricted to the bottom plane in the graphs above.

Phylogeography based on the analysis of DNA sequences from spatially distributed populations is another source of patterns that can be used to evaluate alternative models of speciation. These patterns enable us to estimate the time scale of divergence events, as well as vicariance patterns and population histories. Such studies often show that closely related species or populations do not occupy the same spatial area (i.e., do not occur in sympatry). This is interpreted habitually as the strongest evidence for the ubiquity of allopatric speciation. However, distinct spatial segregation is often maintained in spite of species ranges that shift in response to environmental fluctuations, such as ice-age cycles (Chapter 15). In such situations segregation must be maintained actively and cannot be considered as a simple by-product of previous allopatry. Such active separation mechanisms are



more likely to evolve during an initial sympatric phase under the adaptive speciation scenario, in which assortative mating builds up and results in discrimination between the differently adapted forms. Chapter 7 explains how such sympatric processes of local adaptive diversification can result in patterns of spatial segregation of newly forming species.

The empirical studies in this book were chosen as examples in which adaptive speciation might play an important role, but none of them provides unequivocal proof for the mechanism. Of all the possible empirical approaches, the experiments that involve microorganisms (Chapter 14) will probably enable the most careful control of the conditions required for adaptive speciation. However, we think that adaptive speciation will also be a satisfying explanation for the results of many other studies, even when alternatives cannot be ruled out completely. Future investigations will benefit highly from an intensified interplay between theoretical and empirical work, in particular because this will diminish the risk of biased data acquisition and interpretation that results from self-imposed conceptual restrictions.

## 19.5 Continuous Splitting and Radiations

The adaptive speciation process has an inherent tendency to lead to the continuous splitting of populations. The reason is that, when a population has reached a new adaptive peak, it may well again come into a situation in which intraspecific competition causes disruptive selection. This can lead to a further split, and also the resultant new populations may go through a new cycle. This tendency for continuous splitting will be limited only by the ecological opportunities initially available or becoming available through changes in the biotic environment caused by the diversification process itself. However, once such saturation is attained, many of the then extant lineages are likely to be highly specialized. Since these lineages will be sensitive to even mild environmental perturbations, they can be lost again easily. On this basis, we should expect a pattern of lineage splitting as depicted in Figure 19.1: while a large diversity of lineages can exist at any given time, only a few of these will survive to form deeper splits.

At first sight, it might appear that such a continuous-splitting process is not compatible with the phylogenetic patterns found in nature. At least in the official taxonomy, species are well defined and clearly delimited. But for almost any species it is possible to identify subspecies, or races, that differ in certain characters. Some species appear so variable that they are officially even called “polytypic”. We suggest that this inherent variability can be explained by the continuous-splitting scenario outlined here.

If an environment offers completely new ecological opportunities, the expectation is that newly split lineages are less likely to be lost. Going beyond the small changes that occur under relatively stable conditions, these initial lineages could, rather, be the basis for further specific adaptations. Such cases would become manifest as radiations in the evolutionary history and in the fossil record. Paleontological patterns have been described as punctuated equilibria with periods of

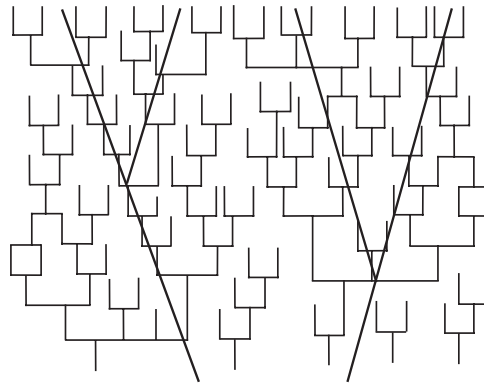

**Figure 19.1** The continuous-splitting scenario. If populations have a continuous tendency to split, closely related sister groups are present at any time. However, because of environmental fluctuations, many of these splits are either lost or merge again. Hence, only a relatively few deeper splits persist in the long run. For example, at the top of the tree, we would count 18 genetically different populations, subspecies, or species (thin lines), but only four taxonomically distinguished species that have descended from deeper splits (thick lines).

fast radiation and generation of morphological diversity, followed by relative stasis with little morphological change. If one envisages evolution and speciation as a continuous process of divergence, this would seem like a paradox. However, this is the expected pattern under the adaptive speciation scenario: when new ecological opportunities open up – for example, when a species colonizes a new area (see Boxes 4.8 and 18.2) – it quickly adapts to the new condition and starts cycles of adaptive speciation that lead to a fast succession of splits until all the available ecological opportunities are taken. Since each cycle of splitting may take less than a thousand generations, such radiation will seem very sudden in the fossil record. As long as there is no further ecological change, new adaptations cannot happen and relative morphological stasis is expected. Moreover, as discussed in Box 4.8, adaptively driven punctuation events also can be triggered by quantitatively minor changes in the geometry of the fitness landscape, which occur in the wake of slow changes in the overall environment. Thus, there is no need to invoke a special macro-evolutionary mechanism, or divergence in peripheral isolates, to explain the pattern of punctuated equilibria encountered in the fossil record.

## 19.6 Future Directions

It is evident that new, dedicated studies are required to better explore the applicability of the adaptive speciation process to a wide range of natural systems. The preceding chapters also highlight a suite of unanswered questions that need to be tackled. Advances are needed with regard to both theoretical and empirical approaches.

Speciation models have come a long way over the past five decades – yet major challenges still remain. The ultimate goal of theoretical endeavors is to catalog the relationship between potential mechanisms and potential phenomena. In the

**Box 19.2** Future theoretical research

In this book we survey a number of processes that can lead to adaptive speciation, and discuss the patterns such processes are expected to generate. We clearly are in the initial phases of this endeavor, and most of the models put forward still require further investigation. Below we outline some of the most interesting options for further theoretical research.

Many questions below extend to sympatric, parapatric, and allopatric speciation and address the following two fundamental issues. First, what genetic, ecological, mating, and spatial structures are particularly conducive to speciation that progresses along certain routes? Second, what are the phylogenetic and biogeographic consequences of such speciation? Answers to these questions will help us evaluate the probabilities of past speciation routes from present observations.

*Speciation genetics.* Responses of alternative genetic architectures to the selection pressures encountered at evolutionary branching points should be analyzed. Forays in this direction have been made by Kawecki (Chapter 3), and by Geritz and Kisdi (2000), who considered adaptive dynamics in allele space in Levene-type models (see Box 4.7). Corresponding multilocus models, comparable to those considered by Dieckmann and Doebeli (Chapter 5), should also be investigated. In this context departures from additive genetics have to be explored and their implications for the potential and pace of adaptive speciation analyzed. In addition, we need better insight into the potential of sex-ratio distorters and selfish elements to promote or prevent adaptive speciation (Chapter 12).

*Evolving mate choice.* Models in which mate choice is based on separate loci for mating signals, mating preferences, and the strength of these preferences need to be integrated with ecological models of adaptive speciation. Also, mate finding and mate recognition could be modeled separately from mate choice. In the real world, the space of phenotypes potentially involved in such processes is often very highly dimensional. The implications of such high dimensionality for the speed at which fitness minima can be escaped need to be analyzed (e.g., Van Doorn *et al.* 2001). Also, general models for speciation based on sexual selection alone have to be developed and studied in greater detail (Van Doorn and Weissing 2001); such models should start to incorporate the frequency dependence that often arises from mate choice. Sexual arms races are one potential mechanism that enables fast allopatric speciation [Schilthuizen 2001; see also Gavrillets (2000b) and Section 5.4]: more mechanistic models that underpin this idea are needed, as well as parapatric and sympatric variants of these models to assess the amount of gene flow under which pairs of arms races can still diverge.

*Speciation, learning, and plasticity.* Models that combine genetic evolution with learning of the ecological role, or with plasticity in an ecologically relevant trait, should be developed and studied. In this context, links with optimal foraging theory should be explored. The same applies to models that combine ecological branching with learned mate selection (e.g., through song learning in birds, or parental imprinting). In general, under what conditions does plasticity or learning help speciation to take off, by allowing species to enter a wider variety of niches, and when does it actually preclude speciation by broadening resource specialization (Chapter 12)? The answer necessarily depends on details of the fitness landscape: plasticity can make a bumpy landscape smoother and so more conducive to evolutionary change (as species do not become stuck on any little hill), but plasticity can also just supply the phenotypic variation otherwise provided by genetic diversification (Chapter 10).

*continued*

**Box 19.2** *continued*

*Patterns, biogeographic and other.* Predictions are needed about the spatial patterns of genetic variation of and linkage disequilibria between ecological and mating characters expected from adaptive speciation. These patterns are likely to depend on the speciation route followed by the process (Chapter 7; Box 19.1); therefore, mechanisms need to be grouped according to the patterns they engender. Predictions that can distinguish ongoing sympatric speciation from secondary contact after incomplete allopatric speciation would be particularly valuable. Also, conditions for the evolution of spatial mosaics through adaptive speciation have to be better understood; these should refer to the ecological mechanism that causes divergence, the movement pattern of individuals, and the underlying environmental heterogeneity. At the temporal end, in allopatric speciation as envisaged in Chapter 6, the average number of speciation events per time unit will probably decrease only slowly over evolutionary time, while the arguments put forward in Box 18.2 suggest that speciation rates decrease very rapidly in sympatric adaptive speciation scenarios. In general, certain phylogenetic features may indicate certain speciation processes – exactly how remains to be determined.

*Speciation time scales.* We need better insight into the time scales of speciation processes as they unfold along different routes. How robust are the salient numerical results, that is, to what extent do they depend on particular model assumptions? For example, how predictions from the models discussed in Chapter 6 depend on the specific assumptions made about the dependence of genetic incompatibility on genetic distance should be resolved. When considering alternative mechanisms – like dominance, sexual dimorphisms, or step-like phenotypic plasticity (Van Dooren 1999; Matessi *et al.* 2001) – that could accomplish splitting a population into a number of discrete morphs, we have to assess how these mechanisms fare when raced against each other in more elaborate ecological models.

*Long-term phylogenetic implications.* It will also be interesting to understand how patterns caused by the various speciation routes considered in this book can themselves act as historical constraints on later developments. This can involve ecological processes (speciation events change the community and may thus prepare the way for further speciation events, either in the descendant species or in other parts of the community), spatial patterns (particular distributions may be more conducive to further speciation than others), and genetic architectures affected by earlier speciation (some such architectures may allow escapes from fitness minima more readily than others, as, for example, when earlier mechanisms for assortative mating help new sorts of assortativeness to start).

*More complex speciation models.* Integration of the various speciation mechanisms into more general models is required. In particular, models for the generation of ecological sister species through sexual selection, like that discussed in Chapter 8, should be combined with models for adaptive speciation caused by ecological factors, to better understand how the processes may interact (Van Doorn and Weissing 2001). Also, with regard to the underlying ecology it is of great importance to assess the robustness of predictions within more extended model families. An interesting development in this direction is that for very large classes of ecological models the local form of invasion fitness is the same (up to second-order terms) as that of a Lotka–Volterra system (Durinx *et al.*, unpublished). This suggests that for particular theoretical problems we can restrict our attention to such approximations of more complex ecologies.

**Box 19.3** Future empirical research

The chapters in this book make clear that, to gain access to more conclusive evidence for particular speciation scenarios, much more attention has to be paid to the earliest phases of the splitting process, which are confined to a few hundred generations after the conditions for splitting have been established. Identifying such situations will be a challenge, but the continuous-splitting scenario (Figure 19.1) suggests that they are not rare. Studying newly colonized habitats will probably provide the best entry point to such situations in nature. Furthermore, because the splitting process is expected to be relatively quick, it will be possible to set up laboratory experiments with rapidly reproducing species that may allow the full speciation process to be followed. Several aspects should be at the top of the agenda for such future empirical research.

*Assortative mating.* For sexually reproducing species, the emergence of assortative mating is a prerequisite for the splitting process. Although assortativeness is a well-known phenomenon in nature, it must now be studied in much more detail and with new conceptual approaches. The simplest assumption would be that signals for assortative mating are coupled pleiotropically to the ecological trait under selection. However, this is not a strict requirement since Dieckmann and Doebeli (1999) showed that such coupling between the ecological trait and specific mating signals can also evolve from scratch. A further alternative is that an assortative mating system is already present, because it evolved in the previous round of speciation. Only minor modifications may be necessary to achieve a further differentiation. It should thus be rewarding to identify situations in which successive speciation events have taken place within a short time and compare the signaling and recognition mechanisms in each of the sister groups. Ethologists know that animals are generally rather choosy when it comes to mating, for good reasons. The choice of the right partner has a direct fitness consequence because it determines the genetic quality of the offspring. The optimal partner for an organism is one that is most compatible with its own genotype, in the sense that the joint offspring are able to compete effectively for the ecological niche that was also used by the parents. This leads to “genotypic assortativeness”, which needs to be coupled to specific signals. Thus, genetic assortativeness can be considered as something that is already built into the system of a sexually reproducing species, and that does not have to evolve newly during a speciation process. In general, a better understanding of the genetics of recognition and signaling is required to investigate ongoing processes of adaptive speciation.

*Genetic incompatibilities.* Although the initial splitting may only involve prezygotic mechanisms and the sorting of pre-existing alleles, it is clear that postzygotic genetic incompatibility evolves at some point. There is increasing evidence that such postzygotic effects are not simply a consequence of the random accumulation of differences, but can be driven by specific genes. One of these, the Odysseus locus in *Drosophila*, is particularly well studied and there is evidence for continuous strong positive selection at this locus, which suggests an active role in the separation process (Ting *et al.* 1998). In future studies, it will be very important to trace the role of such “speciation genes” during the separation process. Can they act as selfish elements that drive separation on its own, such as *Wolbachia* bacteria in insects? Are they part of the assortative mating process by affecting signaling or recognition? Or are they only recruited during a later phase of the separation process?

*continued*

**Box 19.3** *continued*

*Spatial context.* One of the largest challenges for the future is to understand the connection between the splitting processes under conditions of ecological contact and subsequent spatial separation. Clearly, most closely related species do not occur in sympatry and there must therefore be a mechanism that leads to these spatial splits. Modeling efforts in this direction are already well underway (Chapter 7; Doebeli and Dieckmann 2003; M. Rost and M. Lässig, personal communication). For empirical studies, it is particularly important to apply refined molecular markers in the phylogeographic reconstruction of existing patterns of species and population distribution. This will enable situations to be identified at different stages of the separation, or secondary contact process, which can then be studied in detail. In particular, a number of interesting differences in the gene flow patterns for mitochondrial and nuclear markers have now been documented (Shaw 2002; Ogden and Thorpe 2002). These findings might provide vital clues about the role of male and female migration in establishing or obliterating spatial patterns of genetic differentiation.

*Experimental systems.* To study the full process of separation in the laboratory, one will have to resort to organisms with short generation times. The first choice would be viruses, bacteria, or unicellular eukaryotes, such as yeast or algae. They potentially allow each generation to be retained by freezing samples, to carry out replicate experiments under controlled conditions, and possibly to study genetic changes at the genome level. Chapter 14 provides salient examples of how such studies can be used to investigate adaptive speciation and radiation. However, while experimental systems of microorganisms have many advantages for the study of ecological mechanisms of diversification, they have some obvious disadvantages when it comes to the study of assortative mating mechanisms – if only because many microorganisms have irregular and often quite complicated modes of sexual reproduction. It should therefore be attractive to further develop short-lived, sexually reproducing organisms of higher taxa into laboratory models for speciation experiments. *Drosophila* has already been used often for speciation studies, but not in the context of explicit scenarios for adaptive speciation processes. With the availability of the *Drosophila* genome sequence, this system might offer an attractive alternative to studies that focus on unicellular organisms.

best of all worlds we would thus be able to write down and analyze a single, all encompassing family of eco-evolutionary speciation models. This family's parameter space would be parceled up into different regions that correspond to different speciation routes and mechanisms. In practice, however, speciation processes at present appear far too complex and diverse for such an exercise to be feasible yet. At best we can analyze small subsets of the larger family in which we stress some mechanisms at the cost of neglecting others. In a next stage, we may tentatively combine two, or sometimes even more, mechanisms to explore their interactions. Box 19.2 gives an overview of the present and future challenges offered by such a research program.

Future empirical studies will benefit from the analysis of carefully controlled laboratory populations, as well as from the identification of natural situations of ongoing splitting. We need to better understand the specific biological mechanisms that underlie evolutionary branching and the evolution of assortative mating. Although assortative mating and specific mate choice are well known as such, their genetic basis and evolutionary origins now have to be explored in the context of speciation. As discussed in Chapter 1, there are many possibilities as to how assortativeness can come about, so the empirical studies should pay particular attention to these mechanisms. The implied challenges for further empirical research are summarized in Box 19.3.

A key issue for both theory and empirical studies is the inclusion of spatial context. After all, parapatric or allopatric patterns of species distribution are prevalent in nature and need to be explained. The model discussed in Chapter 7 shows that gradients of environmental resource distribution lead to spatial splits under the adaptive speciation scenario (Doebeli and Dieckmann 2003). This line of investigation bears further exploration, and there is a need for empirical studies that analyze the ecological settings prone to such spatial splitting.

The study of speciation mechanisms can be freed finally from the conceptual chains that external causes always have to be invoked as the driving forces of speciation processes. Instead, frequency-dependent selection and evolutionary branching emerge as plausible mechanisms of lineage splits that are adaptive and immanently arise in speciating populations. When the conditions for adaptive speciation are met, the splitting of a population becomes an inescapable consequence of its interacting and reproducing constituents. Speciation is thus a law of nature, rather than an accident.

## References

References in the book in which this chapter is published are integrated in a single list, which appears on pp. 395–444. For the purpose of this reprint, references cited in the chapter have been assembled below.

- Abrams PA, Matsuda H & Harada Y (1993). Evolutionarily unstable fitness maxima and stable fitness minima of continuous traits. *Evolutionary Ecology* **7**:465–487
- Brown JS & Pavlovic NB (1992). Evolution in heterogeneous environments: Effects of migration on habitat specialization. *Evolutionary Ecology* **6**:360–382
- Bush GL (1969). Sympatric host race formation and speciation in frugivorous flies of the genus *Rhagoletis* (Diptera: Tephritidae). *Evolution* **23**:237–251
- Bush GL (1998). The conceptual radicalization of an evolutionary biologist. In *Endless Forms: Species and Speciation*, eds. Howard D & Berlocher S, pp. 425–438. Oxford, UK: Oxford University Press
- Christiansen FB (1991). On conditions for evolutionary stability for a continuously varying character. *The American Naturalist* **138**:37–50
- Durinx M, Metz JAJ & Meszéna G. Adaptive dynamics for physiologically structured population models. Unpublished
- Erwin TL (1982). Tropical forests: Their richness in *Coleoptera* and other arthropod species. *The Coleopterists Bulletin* **36**:74–75
- Eshel I (1983). Evolutionary and continuous stability. *Journal of Theoretical Biology* **103**:99–111
- Feder JL (1998). The apple maggot fly, *Rhagoletis pomonella*: Flies in the face of conventional wisdom about speciation? In *Endless Forms: Species and Speciation*, eds. Howard D & Berlocher S, pp. 130–144. Oxford, UK: Oxford University Press
- Felsenstein J (1981). Skepticism towards Santa Rosalia, or why are there so few kinds of animals? *Evolution* **35**:124–138
- Gavrilets S (2000). Rapid evolution of reproductive barriers driven by sexual conflict. *Nature* **403**:886–889
- Lande R (1979). Quantitative genetic analysis of multivariate evolution, applied to brain:body size allometry. *Evolution* **33**:402–416
- Matessi C, Gimelfarb A & Gavrilets S (2001). Long-term buildup of reproductive isolation promoted by disruptive selection: How far does it go? *Selection* **2**:41–64
- May RM (1990). How many species? *Philosophical Transactions of the Royal Society of London B* **330**:293–304
- Novotny V, Basset Y, Miller SE, Weiblen GD, Bremer B, Cizek L & Drozd P (2002). Low host specificity of herbivorous insects in a tropical forest. *Nature* **416**:841–844.
- Ødegaard F (2000). How many species of arthropods? Erwin's estimate revised. *Biological Journal of the Linnean Society* **71**:583–597
- Ogden R & Thorpe RS (2002). Molecular evidence for ecological speciation in tropical habitats. *Proceedings of the National Academy of Sciences of the USA* **99**:13612–13615
- Rosenzweig ML (1978). Competitive speciation. *Biological Journal of the Linnean Society* **10**:275–289
- Schilthuizen M (2000). Ecotone: Speciation-prone. *Trends in Ecology and Evolution* **15**:130–131
- Schilthuizen M (2001). *Frogs, Flies, and Dandelions: Speciation – The Evolution of New Species*. Oxford, UK: Oxford University Press



- Seger J (1985). Intraspecific resource competition as a cause of sympatric speciation. In *Evolution: Essays in Honor of John Maynard Smith*, eds. Greenwood PJ, Harvey PH & Slatkin M, pp. 45–53. Cambridge, UK: Cambridge University Press
- Shaw KL (2002). Conflict between nuclear and mitochondrial DNA phylogenies of a recent species radiation: What mtDNA reveals and conceals about modes of speciation in Hawaiian crickets. *Proceedings of the National Academy of Sciences of the USA* **99**:16122–16127
- Ting CT, Tsaun SC, Wu ML & Wu CI (1998). A rapidly evolving homeobox at the site of a hybrid sterility gene. *Science* **282**:1501–1504
- Van Dooren TJM (1999). The evolutionary ecology of dominance–recessivity. *Journal of Theoretical Biology* **198**:519–532
- Van Doorn GS & Weissing FJ (2001). Ecological versus sexual selection models of sympatric speciation. *Selection* **2**:17–40
- Van Doorn GS, Luttikhuisen PC & Weissing FJ (2001). Sexual selection at the protein level drives the extraordinary divergence of sex related genes during sympatric speciation. *Proceedings of the Royal Society of London B* **268**:2155–2161